

LINEAR INTEGRATED CIRCUITS

TYPES SN52747, SN72747 DUAL GENERAL-PURPOSE OPERATIONAL AMPLIFIERS

BULLETIN NO. DL-S 7311446, FEBRUARY 1971—REVISED SEPTEMBER 1973

- No frequency Compensation Required
- Low Power Consumption
- Short-Circuit Protection
- Offset-Voltage Null Capability

- Wide Common-Mode and Differential Voltage Ranges
- No Latch-up
- Designed to be Interchangeable with Fairchild μ A747 and μ A747C

description

The SN52747 and SN72747 are dual general-purpose operational amplifiers featuring offset-voltage null capability. Each half is electrically similar to SN52741/SN72741.

The high common-mode input voltage range and the absence of latch-up make the amplifiers ideal for voltage-follower applications. The devices are short-circuit protected and the internal frequency compensation ensures stability without external components. A low-value potentiometer may be connected between the offset null inputs to null out the offset voltage as shown in Figure 3.

The SN52747 is characterized for operation over the full military temperature range of -55°C to 125°C ; the SN72747 is characterized for operation from 0°C to 70°C .

4

FA FLAT PACKAGE OR J, JA, OR N
DUAL-IN-LINE PACKAGE (TOP VIEW)

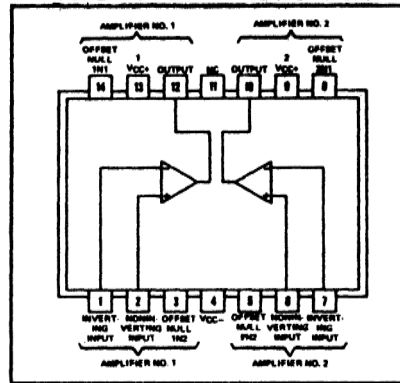

NC—No internal connection
L PLUG-IN PACKAGE (TOP VIEW)

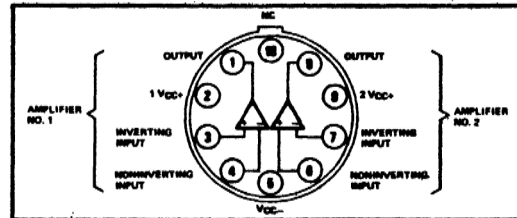

NC—No internal connection

schematic (each amplifier)

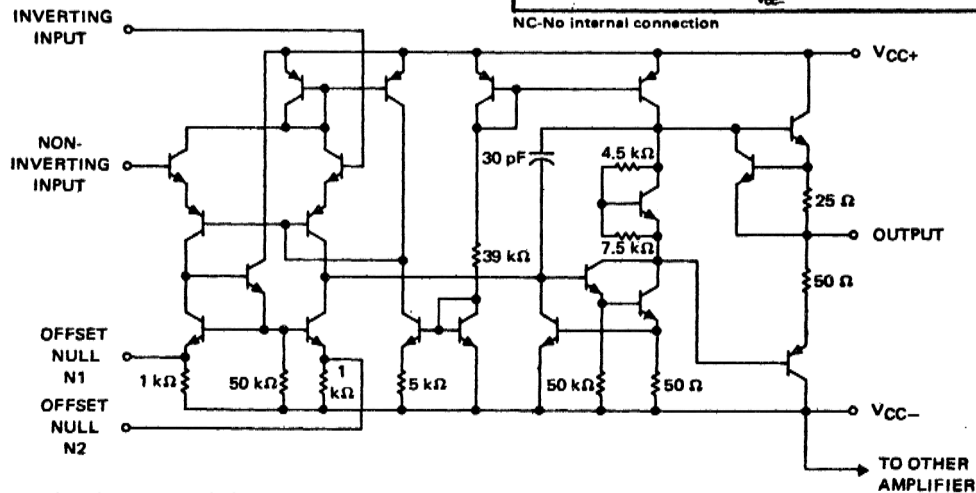

Component values shown are nominal.

TYPES SN52747, SN72747 DUAL GENERAL-PURPOSE OPERATIONAL AMPLIFIERS

absolute maximum ratings over operating free-air temperature range (unless otherwise noted)

	SN52747	SN72747	UNIT
Supply voltage V_{CC+} (see Note 1)	22	18	V
Supply voltage V_{CC-} (see Note 1)	-22	-18	V
Differential input voltage (see Note 2)	± 30	± 30	V
Input voltage any input, (see Notes 1 and 3)	± 15	± 15	V
Voltage between any offset null terminal (N1/N2) and V_{CC-}	± 0.5	± 0.5	V
Duration of output short-circuit (see Note 4)	unlimited	unlimited	
Continuous total dissipation at (or below) 25°C free-air temperature (see Note 5)	Each amplifier	500	mW
	Total package	See Figure 2	
Operating free-air temperature range	-55 to 125	0 to 70	°C
Storage temperature range	-65 to 150	-65 to 150	°C
Lead temperature 1/16 inch from case for 60 seconds	FA, J, JA, or L package		300
Lead temperature 1/16 inch from case for 10 seconds	N package		260

- NOTES: 1. All voltage values, unless otherwise noted, are with respect to the zero reference level (ground) of the supply voltages where the zero reference level is the midpoint between V_{CC+} and V_{CC-} .
 2. Differential voltages are at the noninverting input terminal with respect to the inverting input terminal.
 3. The magnitude of the input voltage must never exceed the magnitude of the supply voltage or 15 volts, whichever is less.
 4. The output may be shorted to ground or either power supply. For the SN52747 only, the unlimited duration of the short-circuit applies at (or below) 125°C case temperature or 75°C free-air temperature.
 5. For operation above 25°C free-air temperature and for total package ratings, refer to Dissipation Derating Curve, Figure 2.

electrical characteristics at specified free-air temperature, $V_{CC+} = 15\text{ V}$, $V_{CC-} = -15\text{ V}$

PARAMETER	TEST CONDITIONS†	SN52747			SN72747			UNIT
		MIN	TYP	MAX	MIN	TYP	MAX	
V_{IO} Input offset voltage	$R_S < 10\text{ k}\Omega$	25°C	1	5	1	6	mV	
		Full range		6		7.5		
$\Delta V_{IO(\text{adj})}$ Offset voltage adjust range		25°C	± 15		± 15		mV	
I_{IO} Input offset current		25°C	20	200	20	200	nA	
		Full range		500		300		
I_{IB} Input bias current		25°C	80	500	80	500	nA	
		Full range		1500		800		
V_I Input voltage range		25°C	± 12	± 13	± 12	± 13	V	
		Full range		± 12		± 12		
V_{OPP} Maximum peak-to-peak output voltage swing	$R_L = 10\text{ k}\Omega$	25°C	24	28	24	28	V	
	$R_L > 10\text{ k}\Omega$	Full range	24		24			
	$R_L = 2\text{ k}\Omega$	25°C	20	26	20	26		
	$R_L > 2\text{ k}\Omega$	Full range	20		20			
A_{VD} Large-signal differential voltage amplification	$R_L > 2\text{ k}\Omega$, $V_O = \pm 10\text{ V}$	25°C	50,000	200,000	50,000	200,000		
		Full range	25,000		25,000			
r_i Input resistance		25°C	0.3	2	0.3	2	M Ω	
r_o Output resistance	$V_O = 0\text{ V}$, See Note 6	25°C		75		75	Ω	
C_i Input capacitance		25°C		1.4		1.4	pF	
CMRR Common-mode rejection ratio	$R_S < 10\text{ k}\Omega$	25°C	70	90	70	90	dB	
		Full range	70		70			
$\Delta V_{IO}/\Delta V_{CC}$ Supply voltage sensitivity	$R_S < 10\text{ k}\Omega$	25°C	30	150	30	150	$\mu\text{V/V}$	
		Full range		150		150		
I_{OS} Short-circuit output current		25°C	± 25	± 40	± 25	± 40	mA	
I_{CC} Supply current (each amplifier)	No load, No signal	25°C	1.7	2.8	1.7	2.8	mA	
		Full range		3.3		3.3		
P_D Power dissipation (each amplifier)	No load, No signal	25°C	50	85	50	85	mW	
		Full range		100		100		
V_{O1}/V_{O2} Channel separation		25°C		120		120	dB	

† All characteristics are specified under open-loop operation. Full range for SN52747 is -55°C to 125°C and for SN72747 is 0°C to 70°C.
 NOTE 6: This typical value applies only at frequencies above a few hundred hertz because of the effects of drift and thermal feedback.
 For definitions of terms, see the SN52741/SN72741 data sheet, page 4-69.

TYPES SN52747, SN72747

DUAL GENERAL-PURPOSE OPERATIONAL AMPLIFIERS

operating characteristics, $V_{CC+} = 15\text{ V}$, $V_{CC-} = -15\text{ V}$, $T_A = 25^\circ\text{C}$

PARAMETER	TEST CONDITIONS	SN52747			SN72747			UNIT
		MIN	TYP	MAX	MIN	TYP	MAX	
t_r	Rise time	$V_i = 20\text{ mV}$, $R_L = 2\text{ k}\Omega$,			0.3			μs
	Overshoot	$C_L = 100\text{ pF}$, See Figure 1			5%			
SR	Slew rate at unity gain	$V_i = 10\text{ V}$, $R_L = 2\text{ k}\Omega$,			0.5			$\text{V}/\mu\text{s}$
		$C_L = 100\text{ pF}$, See Figure 1						

PARAMETER MEASUREMENT INFORMATION

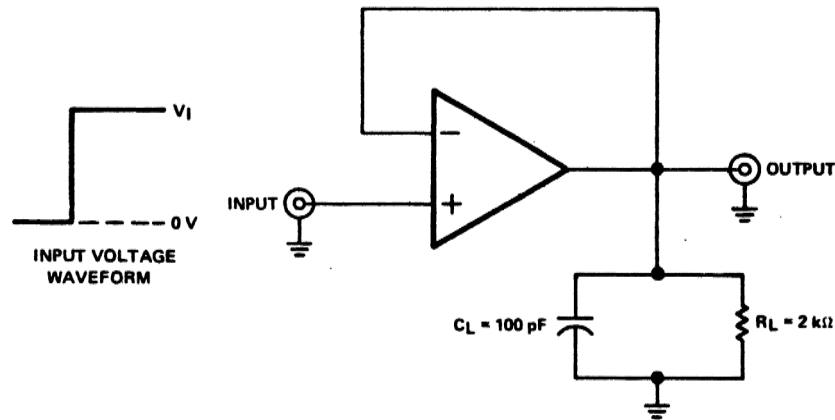

TEST CIRCUIT

FIGURE 1—RISE TIME, OVERSHOOT, AND SLEW RATE

THERMAL INFORMATION

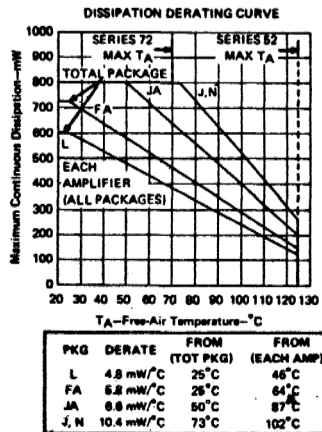

FIGURE 2

TYPICAL APPLICATION DATA

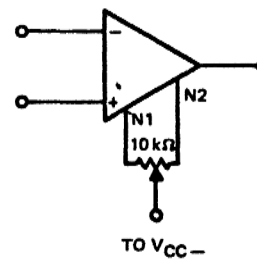

FIGURE 3—INPUT OFFSET VOLTAGE NULL CIRCUIT

TYPES SN52747, SN72747 DUAL GENERAL-PURPOSE OPERATIONAL AMPLIFIERS

TYPICAL CHARACTERISTICS

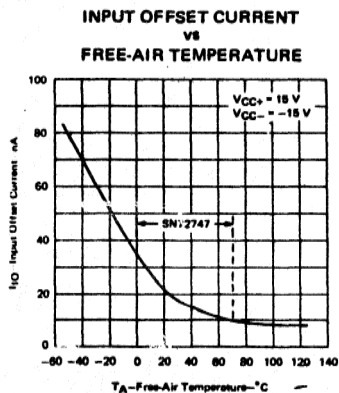

FIGURE 4

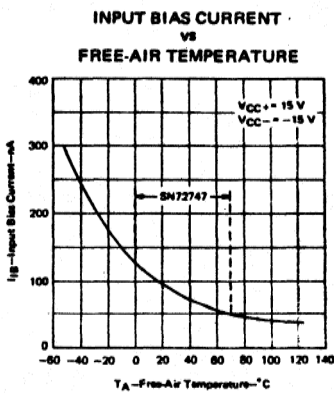

FIGURE 5

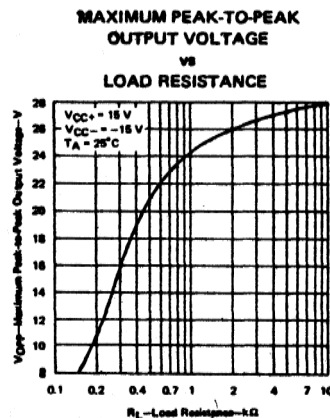

FIGURE 6

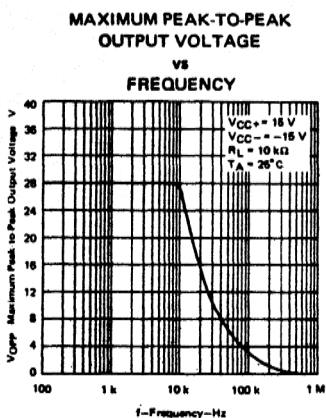

FIGURE 7

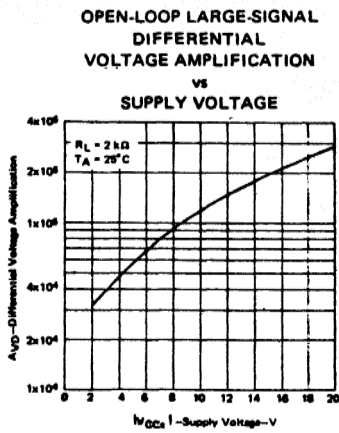

FIGURE 8

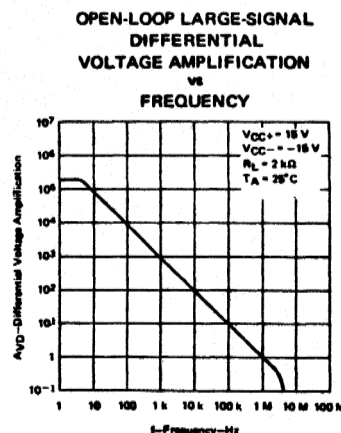

FIGURE 9

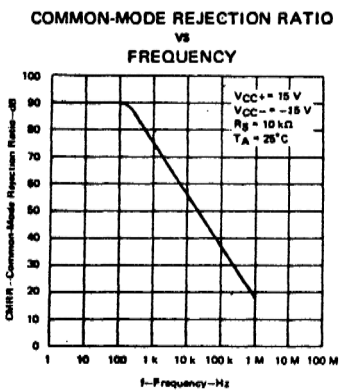

FIGURE 10

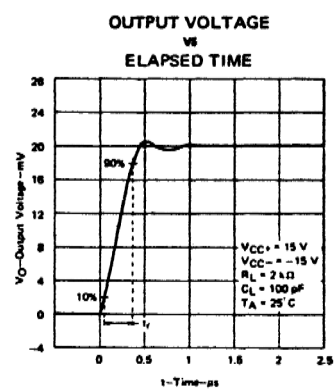

FIGURE 11

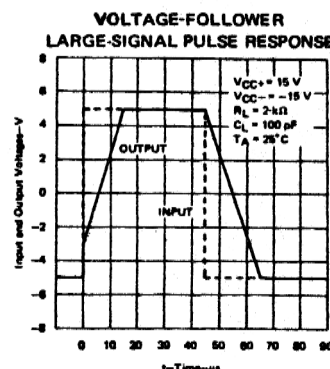

FIGURE 12

PRINTED IN U.S.A.

TI cannot assume any responsibility for any circuits shown or represent that they are free from patent infringement.

TEXAS INSTRUMENTS RESERVES THE RIGHT TO MAKE CHANGES AT ANY TIME IN ORDER TO IMPROVE DESIGN AND TO SUPPLY THE BEST PRODUCT POSSIBLE.

TEXAS INSTRUMENTS
INCORPORATED

POST OFFICE BOX 5012 • DALLAS, TEXAS 75222